

Molded Fiberglass Grating

Molded fiberglass grating provides a cost effective solution and long lasting performance for many industrial and recreational applications. Fiberglass offers superior strength and durability in corrosive environments compared to traditional metal grating.

Molded grating is constructed in one piece from continuous fiberglass rovings and a wide range of premium polyesters or vinyl ester resins. A unique three step weaving process ensures that all glass reinforcements are lined up in the center of bars and protected by the outer resin layers. All grating is tested by independent third-party companies to testing standards set forth by the Fiberglass Grating Manufacturers Council.

Quality and customer service are what set North American Grating above everyone else. We strive to offer a level of customer service that exceeds the customer's expectations. Located in Abita Springs, Louisiana we offer expedited delivery on all stock items being shipped domestically.

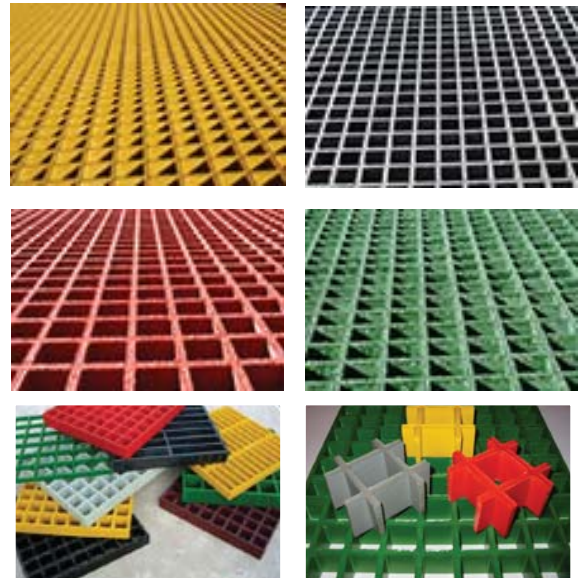

Applications

- Chemical Plants
- Marine/Offshore
- Petrochemical Plants
- Agricultural
- Pulp & Paper Mills
- Water Treatment Plants
- Processing Plants
- Oil Rigs
- Food Processing
- Power Plants
- Brewing & Distillery
- Pigments & Dyes
- Fisheries
- Chemical Fertilizers
- Sewage Treatment Plants
- Air Pollution Control
- Caustic & Chlorine

Stock Panel Selection

* Other grating profiles and panel sizes available upon request.

Part Number	Thickness (in)	Mesh Size (in)	Panel Size (ft)	Color	Resin Type	Surface Finish
MG1015-PP-Y-310	1.0	1.5 X 1.5	3 X 10	Yellow	Premium Polyester	Concave or Gritted
MG1015-PP-DGY-310	1.0	1.5 X 1.5	3 X 10	Dark Gray	Premium Polyester	Concave or Gritted
MG1015-PP-Y-48	1.0	1.5 X 1.5	4 X 8	Yellow	Premium Polyester	Concave or Gritted
MG1015-PP-DGY-48	1.0	1.5 X 1.5	4 X 8	Dark Gray	Premium Polyester	Concave or Gritted
MG1015-PP-Y-412	1.0	1.5 X 1.5	4 X 12	Yellow	Premium Polyester	Concave or Gritted
MG1015-PP-DGY-412	1.0	1.5 X 1.5	4 X 12	Dark Gray	Premium Polyester	Concave or Gritted
MG1515-PP-Y-310	1.5	1.5 X 1.5	3 X 10	Yellow	Premium Polyester	Concave or Gritted
MG1515-PP-DGY-310	1.5	1.5 X 1.5	3 X 10	Dark Gray	Premium Polyester	Concave or Gritted
MG1515-PP-Y-48	1.5	1.5 X 1.5	4 X 8	Yellow	Premium Polyester	Concave or Gritted
MG1515-PP-DGY-48	1.5	1.5 X 1.5	4 X 8	Dark Gray	Premium Polyester	Concave or Gritted
MG1515-PP-Y-412	1.5	1.5 X 1.5	4 X 12	Yellow	Premium Polyester	Concave or Gritted
MG1515-PP-DGY-412	1.5	1.5 X 1.5	4 X 12	Dark Gray	Premium Polyester	Concave or Gritted
MG2020-PP-Y-GT-412	2.0	2.0 X 2.0	4 X 12	Yellow	Premium Polyester	Gritted

* Vinyl ester & general polyester resin available by request.

Key Features

Corrosion & Chemical Resistant

Molded grating is manufactured with continuous glass fiber strands wetted thoroughly with premium grade polyester resin. Such inherent characteristics ensure excellent corrosion resistance over a wide pH range both acidic and caustic.

Great Tensile Strength

A three step continuous fiberglass strand alternating layers and ultimate one piece construction distributes loads to bi-directional bars for greater tensile strength.

Impact Resistant

Unlike metallic grating which will deform and need replacement over time, impact resistance fiberglass grating allows for repeated deflections without permanent deformation.

Fire Retardant

All molded grating resins have a class 1 flame spread rate of 25 or less, per ASTM E84.

Non-Conductive

Molded grating is ideal for electrically hazardous locations. Its inherent properties reduce the risk of electrical shock by acting as an insulator between conductive materials.

Slip Resistant

Two different surface types are available to offer maximum slip resistance for any application. The built-in concave surface offers adequate protection for most applications. The grit surface will provide excellent slip resistance and last longer from normal wear and tear.

Non- Magnetic

Molded grating can be used in sensitive areas where the inherent magnetic properties of traditional metal grating could prove lethal.

Non-Sparking

Molded grating is well suited for applications in which sparks may trigger explosions or fires due to build-up of combustible gases.

Maintenance Free

Molded grating offers a maintenance free alternative to metallic grating due to its inherent ultraviolet resistance characteristics and corrosion/rust resistance properties.

Easy Installation & Fabrication

Molded grating weights about one-fourth that of traditional metal grating. This makes installation and fabrication easily accomplished with no more than two people and standard equipment.

Color Selection



Yellow



Dark Gray



Orange



Green

Surface Selection



Concave

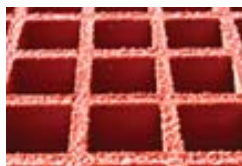

Gritted

Load Table

MG1015 - 1.0" THICK 1.5" x 1.5" SQUARE MESH													
SPAN INCHES		LOAD IN LBS - DEFLECTION IN INCHES										MAXIMUM RECOMMENDED	ULTIMATE CAPACITY
		50	100	150	200	300	400	600	800	1000	1200	LBS	LBS
12	ΔU	0.004	0.009	0.013	0.018	0.026	0.037	0.051	0.073	0.089	0.100	1350	6750
	ΔC	0.008	0.015	0.021	0.026	0.042	0.054	0.083	0.106	0.138	0.165	670	3350
18	ΔU	0.022	0.042	0.063	0.083	0.124	0.165	0.243	0.325	0.406	0.485	650	3250
	ΔC	0.023	0.045	0.067	0.089	0.132	0.178	0.260	0.355	0.437	0.518	498	2490
24	ΔU	0.063	0.127	0.193	0.256	0.386	0.511	0.770				377	1885
	ΔC	0.051	0.101	0.153	0.203	0.307	0.411	0.612				377	1885
30	ΔU	0.154	0.308	0.463	0.618							235	1175
	ΔC	0.098	0.196	0.296	0.394	0.595						297	1485
36	ΔU	0.312	0.629									158	790
	ΔC	0.167	0.337	0.501	0.668							237	1185

Specifications

Number of bars per ft = 8

Load bar thickness = 0.26" / 0.2"

Load bar center-to-center = 1.5"

Cross bar thickness = 0.26" / 0.2"

Cross bar center-to-center = 1.5"

Open Area = 68%

Approx. Weight = 2.5 lbs/ft²

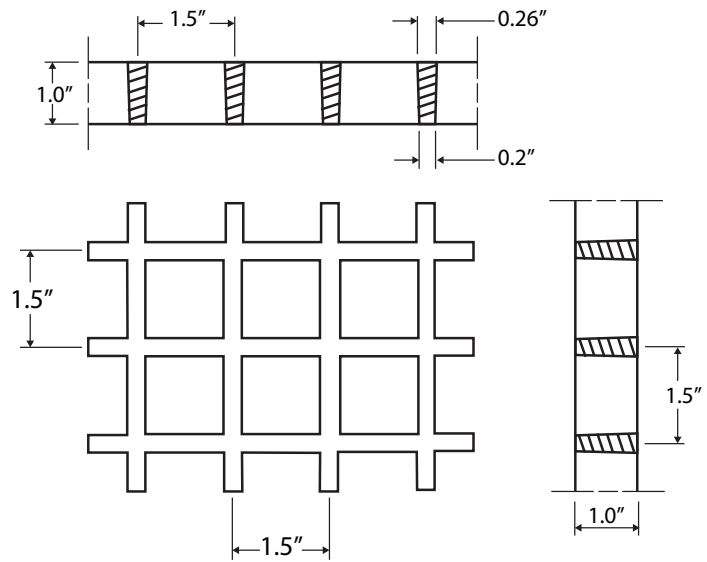

Load Table Data

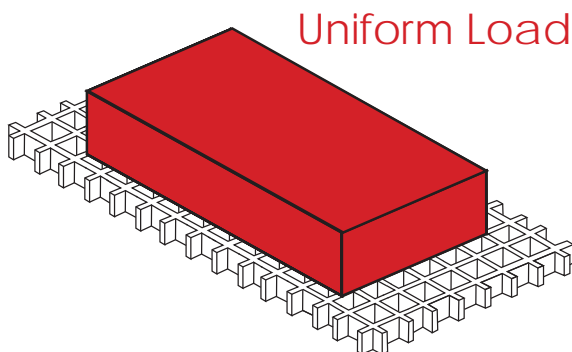

Uniform Load

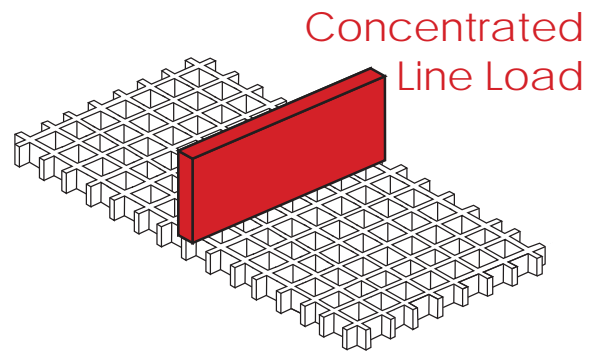

Concentrated Line Load

U = Uniform load - lbs/ft of width
 ΔU = Uniform load deflection (in/mm)

C = Concentrated line load - lbs/ft
 ΔC = Concentrated line load deflection (in/mm)

Load Table

MG1515 - 1.5" THICK 1.5" x 1.5" SQUARE MESH

SPAN INCHES		LOAD IN LBS - DEFLECTION IN INCHES										MAXIMUM RECOMMENDED	ULTIMATE CAPACITY
		50	100	150	200	300	400	600	800	1000	1200	LBS	LBS
12	ΔU	0.002	0.005	0.006	0.009	0.012	0.017	0.023	0.033	0.041	0.045	2070	10350
	ΔC	0.003	0.007	0.009	0.012	0.017	0.023	0.032	0.045	0.055	0.062	1550	7750
18	ΔU	0.008	0.015	0.022	0.029	0.044	0.057	0.085	0.111	0.142	0.166	1370	6850
	ΔC	0.009	0.017	0.025	0.032	0.048	0.062	0.090	0.119	0.149	0.178	1030	5150
24	ΔU	0.022	0.042	0.064	0.086	0.126	0.165	0.248	0.331	0.415	0.494	775	3875
	ΔC	0.016	0.032	0.048	0.063	0.095	0.125	0.188	0.252	0.312	0.388	775	3875
30	ΔU	0.046	0.093	0.140	0.188	0.283	0.377	0.565	0.751			491	2455
	ΔC	0.029	0.060	0.090	0.120	0.180	0.239	0.359	0.479	0.588	0.718	615	3075
36	ΔU	0.094	0.189	0.282	0.382	0.571	0.759					338	1690
	ΔC	0.049	0.099	0.149	0.199	0.299	0.399	0.588				516	2580
42	ΔU	0.173	0.347	0.519								248	1240
	ΔC	0.078	0.155	0.239	0.312	0.468	0.618					438	2190
48	ΔU	0.278	0.569									168	840
	ΔC	0.112	0.225	0.333	0.449	0.672						338	1690

Specifications

Number of bars per ft = 8

Load bar thickness = 0.28" / 0.2"

Load bar center-to-center = 1.5"

Cross bar thickness = 0.28" / 0.2"

Cross bar center-to-center = 1.5"

Open Area = 67%

Approx. Weight = 3.8 lbs/ft²

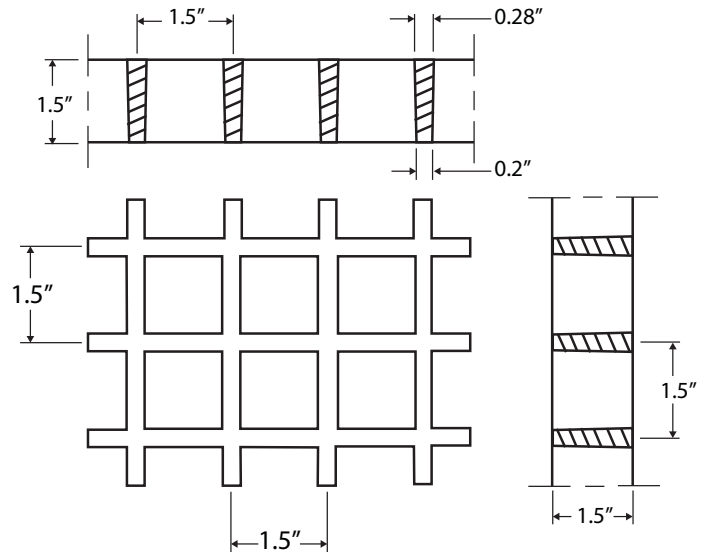

Load Table

MG2020 - 2.0" THICK 2.0" x 2.0" SQUARE MESH

SPAN INCHES		LOAD IN LBS - DEFLECTION IN INCHES										MAXIMUM RECOMMENDED LBS	ULTIMATE CAPACITY LBS
		50	100	150	200	300	400	600	800	1000	1200		
12	ΔU	0.001	0.002	0.003	0.004	0.006	0.008	0.011	0.015	0.020	0.023	2170	10830
	ΔC	0.002	0.004	0.006	0.009	0.011	0.017	0.023	0.032	0.039	0.043	1630	8250
18	ΔU	0.004	0.009	0.013	0.017	0.025	0.032	0.049	0.063	0.083	0.095	1388	7940
	ΔC	0.004	0.010	0.014	0.019	0.027	0.037	0.053	0.071	0.091	0.105	1356	6780
24	ΔU	0.011	0.022	0.033	0.043	0.065	0.083	0.125	0.163	0.211	0.245	956	4780
	ΔC	0.008	0.016	0.023	0.031	0.047	0.062	0.095	0.131	0.158	0.189	956	4780
30	ΔU	0.022	0.044	0.065	0.089	0.128	0.183	0.262	0.363	0.439	0.522	637	3185
	ΔC	0.014	0.027	0.042	0.058	0.086	0.117	0.174	0.231	0.291	0.346	792	3960
36	ΔU	0.043	0.083	0.133	0.177	0.266	0.354	0.530	0.707			458	2290
	ΔC	0.025	0.049	0.071	0.095	0.141	0.189	0.282	0.375	0.471	0.562	677	3385
42	ΔU	0.080	0.163	0.245	0.328	0.489	0.653					338	1690
	ΔC	0.035	0.072	0.109	0.148	0.223	0.289	0.445	0.595			577	3885
48	ΔU	0.132	0.266	0.401	0.532							259	1295
	ΔC	0.049	0.106	0.157	0.211	0.312	0.422	0.626				517	2585
54	ΔU	0.205	0.416	0.622								200	1000
	ΔC	0.071	0.144	0.222	0.194	0.444	0.588					457	2285

Specifications

Number of bars per ft = 6

Load bar thickness = 0.33" / 0.23"
(Top/Bottom)

Load bar center-to-center = 2.0"

Cross bar thickness = 0.33" / 0.23"

Cross bar center-to-center = 2.0"

Open Area = 69%

Approx. Weight = 5.3 lbs/ft²

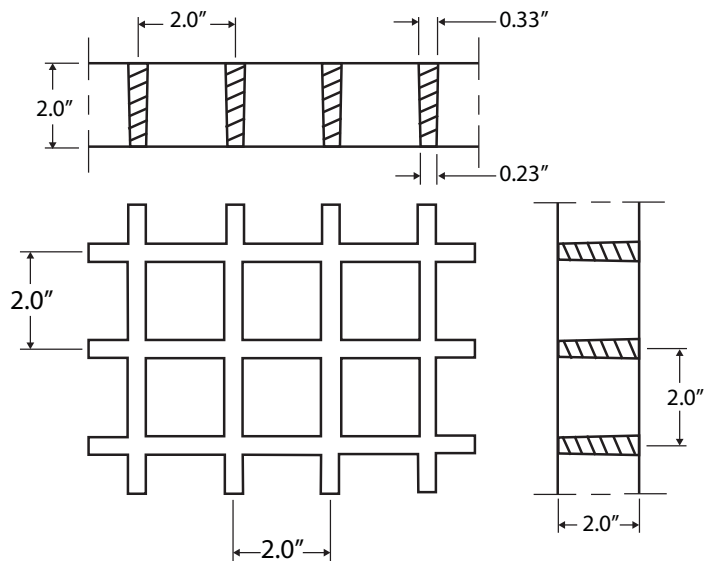

Resin Selection

Type VE is a vinyl ester resin specifically engineered to provide premium service in highly corrosive environments. It utilizes an advanced resin system which delivers outstanding resistance to a wide range of harsh corrosive environments ranging from acidic to caustic. Vinyl ester resin also offers a high level of solvent resistance. It has a Class 1 flame spreading rate of 25 or less according to the ASTM E84 standard method for surface burning. Vinyl Ester is a popular choice for most applications due to its excellent corrosion resistance properties and relative low cost.

Type PP is a premium isophthalic polyester resin. It is a popular choice for most applications due to its good corrosion resistance properties and relative low cost. This type of resin is most commonly used in applications where there is a possibility of a splash or spill of harsh chemicals.

Clips & Accessories

M-Clips

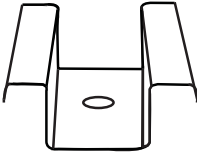

Sizes	
1"	SMC10
1-1/2"	SMC15
2"	SMC20

Model: SMC

- 316 Stainless Steel
- Typically used for attaching grating to structural supports
- Available in 3 sizes

J-Clips

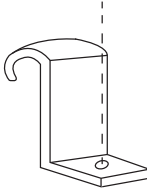

Sizes	
1"	SJC10
1-1/2"	SJC15
2"	SJC20

Model: SJC

- 316 Stainless Steel
- Typically used for attaching grating to structural supports for light to moderate loads
- Available in 3 sizes

C-Clips

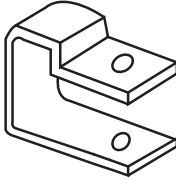

Sizes	
1"	SCC10
1-1/2"	SCC15
2"	SCC20

Model: SCC

- 316 Stainless Steel
- Typically used for joining two panels together
- Available in 3 sizes

Curb Angle

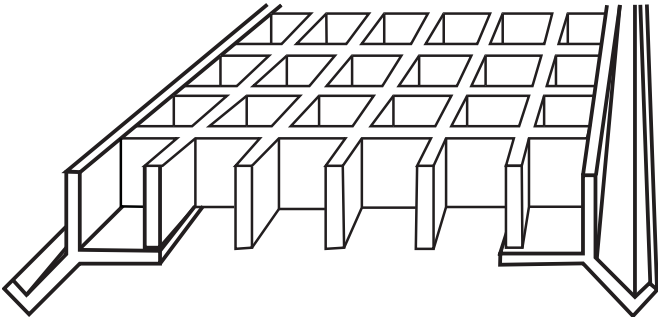

Features

- Pultruded Fiberglass curb angle
- Provides a strong and sturdy base for molded grating
- Typically used in drainage and structural applications
- Available in 3 sizes